

imanpack

PACKAGING & ECO SOLUTIONS

MICROPAC LTS

Long sealing time Flow-wrapper
(HFFS)

Micropac Lts horizontal wrapping machine suitable for wrapping solid products with polypropylene, polyethylene or laminated film.



Product range

Length: from 80 to 600 mm

Width: from 40 to 180 mm

Height: up to 100 mm

Speed

Up to 40 pack./min





ACCESSORIES

- Automatic feeder system.
- European hole punch.
- Labelling and printing machines.
- Gas supply system.
- Print centering photocell.

TECHNICAL FEATURES

- Base in painted metal steelwork.
- PLC with Imanpack user interface.
- Three-phase motor with regulator inverter.
- Longitudinal sealing unit adjustable in height with two couples of heat sealing wheels and two flap folding wheels.
- Long sealing time transversal sealing unit.
- Universal adjustable forming unit.
- Machine built according to CE Standards.

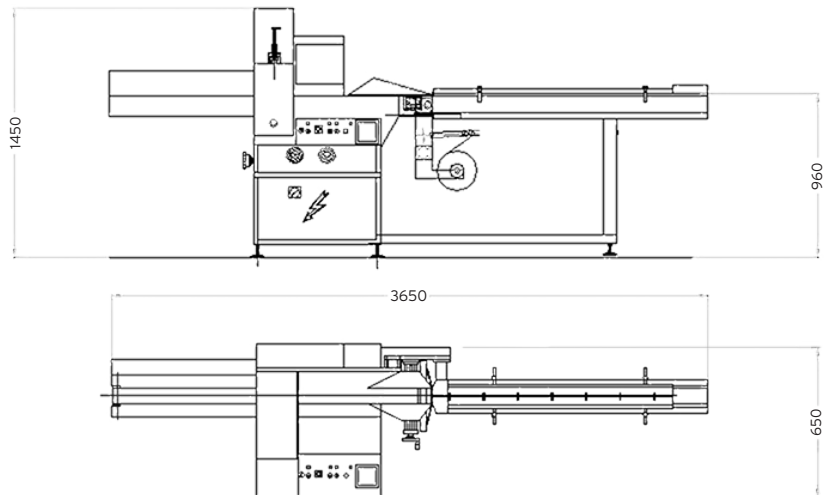

layout

imanpack

PACKAGING & ECO SOLUTIONS

Via Lago di Bolsena, 19 36015 Schio (VI) ITALY
Tel. +39.0445.578.811 Fax+39.0445.575.111
www.imanpack.it email: info@imanpack.it