

imanpack

PACKAGING & ECO SOLUTIONS

JUMBO MULTIPACK

Special Bundle-Pack Flow-wrapper (HFFS)

Intermittent movement horizontal wrapping machine suitable for wrapping large size products in multiple packages using polyethylene film. It can replace cardboard boxes which generates packaging savings.



Product range
Multiple diaper packs



TECHNICAL FEATURES

- Manual loading station.
- Fixed forming unit.
- Pusher driven by servomotors to transfer the product through the forming tunnel towards the transversal sealing unit.
- Product compacting unit.
- Motorised reel holder unit.
- Forming tunnel with power driven film feed conveyor belt unit, controlled by servomotors and synchronized with the pusher unit.
- Pulse transversal sealing unit with pneumatic cutter.
- Mechanical blowers.
- Longitudinal sealing unit with heated teflon bar with thermoregulator control.
- Discharge conveyor belt.
- Machine built according to CE Standards.

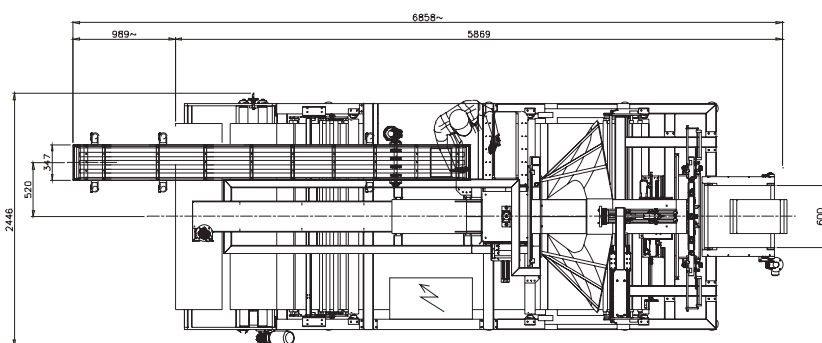
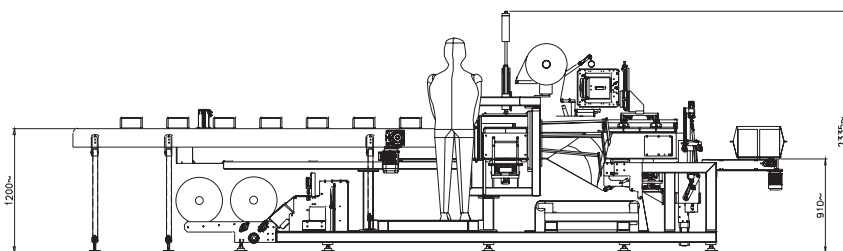

layout

imanpack

PACKAGING & ECO SOLUTIONS

Via Lago di Bolsena, 19 36015 Schio (VI) ITALY
Tel. +39.0445.578.811 Fax+39.0445.575.111
www.imanpack.it email: info@imanpack.it

OPTIONS

- Automatic feeder.
- Automatic reel change.
- Thermal bar code printer.
- Carrying handle application.