

# imanpack

PACKAGING & ECO SOLUTIONS

## MICROPACK PRO

### Flow-wrapper (HFFS)

Rotary flow-wrapper suitable for wrapping solid products in general using heat sealing or polyethylene film. Control and command via PLC.

Can be connected to automated production lines.



#### Product Range

Width: up to 180 mm

Length: from 20 mm

Height: up to 120 mm

#### Speed

Up to 250 bags/min





## ACCESSORIES

- Full AISI 304 inox version.
- Automatic loaders.
- Different conveyor belt lengths.
- Motorized reel unwinder with inverter.
- Printers and labellers.
- Motorized output conveyor belt with inverter.
- "No product - no bag" system.

## TECHNICAL FEATURES

- Mainframe in painted steel.
- Paddle wheel conveyor belt 1500 mm long in AISI 304 steel.
- Food grade plastic rapid extraction product pushers.
- Electronic pitch adjustment.
- Top or bottom reel holder with pneumatic opening for reels up to 500 mm wide.
- Electronic torque limiter.
- Longitudinal sealing unit with pre-heated drive wheel, heat sealing wheel and flap folding wheel.
- Rotary cross sealing unit with 250 mm sealing jaw, with electronic thermoregulator control.
- Independent axes motors for:
  - Conveyor belt
  - Longitudinal sealing unit
  - Cross sealing unit
- Universal adjustable forming unit.
- Output conveyor belt, 1000 mm long.
- 7" touch-screen control panel.
- Plastic material incident guards with safety micro switch.
- Integrated electrical system detached from any mechanical parts.
- Machine built according to CE Standards.

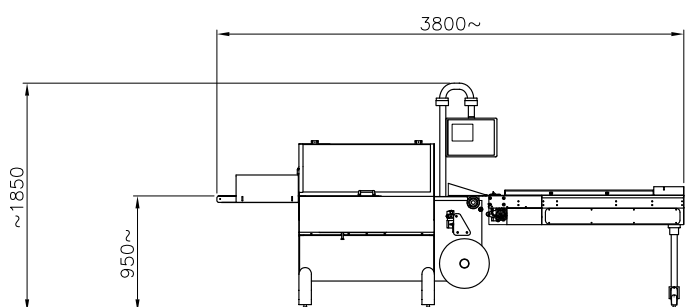
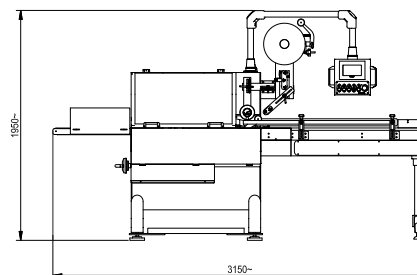

layout

# imanpack

**PACKAGING & ECO SOLUTIONS**

Via Lago di Bolsena, 19 36015 Schio (VI) ITALY  
 Tel. +39.0445.578.811 Fax+39.0445.575.111  
 www.imanpack.it email: info@imanpack.it